

Mechanical Integration

The light is equipped with 4 combined mounting positions of M5 threaded holes and M4 through holes. It can be used to fix the lighting to the specified position. To secure a long live time additional heat transfer measurements at the holding positions is highly recommended.

Example: Model SRL-07

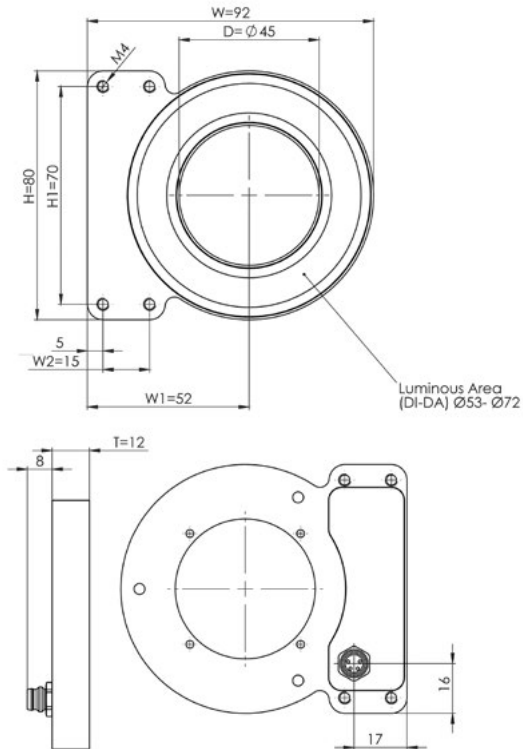

More 2D and 3D drawings can be found online:
www.mbj-imaging.com

Safety Notes

Before working with this unit, read the warning and application instructions carefully and completely before operating the device.



1. The device is designed for indoor use only.
2. **Light** - Due to the risk of flash burn of the eyes it is not recommended to look directly into the light source. The lighting must be switched off before installation and/or maintenance. The device must not be used when a failure may cause a personal injury.
3. **Heat** - In case of insufficient heat dissipation or when running the light in flash mode with a too high duty cycle, the surface temperature may exceed 60 °C. Keep off flammable materials at any time.
4. **Electricity** - The housing is electrically isolated from the ground of the power supply. Exceeding the permissible input voltage U_{in} or $U_{LED(+)}$ can lead to the destruction of the device or to a significant shortening of the lifetime of the LEDs in the device.
5. **Usage** - Please prevent mechanical stress to the light surface during operation. This will lead to an inhomogenous light emission.
6. **Cleaning** - The light emission surface has to be cleaned with a standard glass cleaner and a soft cleaning cloth. Do not use other material for cleaning as it will damage the device.

Manual SRL RingLight Series: Revision 04 - 20 January 2021. INDD File Rev07.

MBJ Imaging GmbH

Jochim-Klindt-Strasse 7 +49 41 02 77 89 0 - 31
 22926 Ahrensburg, Germany sales@mbj-imaging.com
www.mbj-imaging.com



Operating Manual
 Technical Data

Ring Light Series



Model Sizes in Series

The illumination is available in the following sizes ¹⁾

SRL-04	SRL-07	SRL-12

¹⁾ size definition refers to the center light field diameter

Possible LED Colors

LED	Abbr. ¹⁾	Peak Wavelength ²⁾
White	-WT	5000K, CRI80
Red	-RD	near 625nm
Infrared	-IR	near 850nm
Green	-GN	near 525nm
Blue	-BE	near 465nm
Yellow	-YE	near 580nm

¹⁾ Color option will be added to the model name after the size information. DBL-1010-IR refers to a back light with 850nm infrared light

²⁾ This is an approximated value. The exact value also depends on LED temperature and LED current

Electrical Connection

The lighting is equipped with an 4 pin M8x1 connector.

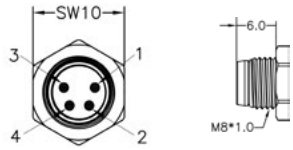

Pin	Color ¹⁾	Standard (-s)	Direct (-x) ²⁾
1	brown	24 VDC	LED (+)
2	white	Dim	LED (+)
3	blue	Trigger	LED (-)
4	black	Ground	LED (-)

1) wire color of MBJ lighting cable

2) connection to 24VDC without external LED controller may destroy the unit

Additional Information:

Pin3 (Trigger) is an 'active high' input signal with 5...24V=ON and 0...1V=OFF, it is a high resistance current sink with 0.2mA for 5V and 5mA for 24V

Pin2 (DIM) is used as brightness control and operation mode switch, it is a high resistance current sink with 0.2mA for 5V and 1mA for 24V.

For the connection it is recommended to use the MBJ lighting cable with a maximum length of 10m.

SRL-04: due to the small size of this ring light the -s controller is integrated into the cable (cable controller)

Integrated Controller (-s)

Supported operation modes with the integrated LED controller

Pin 2 (Dim)	Operation mode
24V	steady light ¹⁾
1...10V	steady light with brightness control ²⁾
24V	triggered light
GND	triggered flash light with max. 20ms and up-to 100% more light intensity ³⁾

1) Pin 3 (Trigger) needs permanent 24V to activate steady light mode

2) PWM with 3.8kHz clock is used, recommended minimal camera exposure is 5ms

3) latency between trigger and LED light ON is about 20...30µs, the maximum recommended clock speed is 1 kHz, the maximum recommended duty cycle is 25% and the minimum recommended flash time is 100µs

Application Samples for (-s) controller

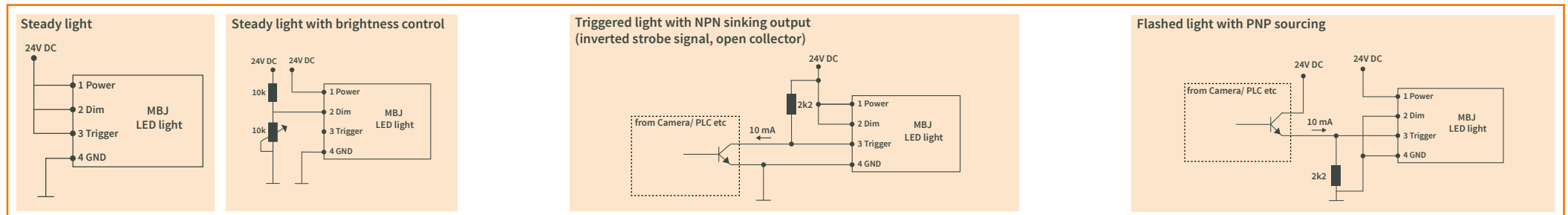

Specification	SRL-04	SRL-07	SRL-12
Optical parameter			
Luminous area (DI-DA)	36mm - 52mm	53mm - 72mm	87mm - 121mm
Light emission	ring shaped light field with direct fired LED, diffuse emission		
Recommended use	commonly used as incident light for brightfield application, placed around the MV camera, e.g. for OCR or print inspection		
Luminous Flux of white LEDs [lumen] ¹⁾	460lm	920lm	1840lm
Radiant Power of red LEDs [mW] ¹⁾	1350mW	2700mW	5410mW
Radiant Power of IR LEDs [mW] ¹⁾	650mW	1300mW	2600mW
Electrical parameter			
Available interfaces	-s with integrated LED Controller and 4 operation modes; -x with direct LED access (external LED control is required)		
Uin for -s Version	24V DC +/- 10%		
U _{LED(+)} range for -x version ²⁾	WT / BE / YE: 17 ... 20 VDC; GN: 20 ... 23 VDC; RD: 12 ... 15 VDC; IR: 9 ... 12 VDC		
Typical Power (-s version)			
Steady light operation	3W	6W	11W
During ON time at flashed light operation	8W	15W	25W
Recommended LED current (-x version)			
Steady light (100% duty cycle)	150mA	300mA	600mA
Flash light (50% duty cycle, 500ms pulse)	300mA	600mA	1200mA
Flash light (25% duty cycle, 50ms pulse)	450mA	900mA	1800mA
General parameter			
Dimension (H x W x D)	60mm x 60mm x 12mm	80mm x 92mm x 12mm	130mm x 141mm x 14mm
Lens hole diameter [D]	34mm	45mm	80mm
Weight	60g ³⁾	120g	300g
Material	Anodized aluminum housing with PMMA light cover		
Connector	M8x1 socket, 4 pin, male (pinning details on the next page)		
Operating temperature	10°C to 30°C		
Certifications	CE, RoHS		
Degree of protection	IP54		
Humidity	30% to 70%		
Accessories	For cable, mounts and LED controller please check www.mbj-imaging.com		

1) Values are approximate with a +/- 7% tolerance

2) Lower voltage value refers to steady light, higher voltage value refers to flash light, please see max. allowed current in the row below

3) without cable controller